

VISTA FRONTAL
ESC. 1:15

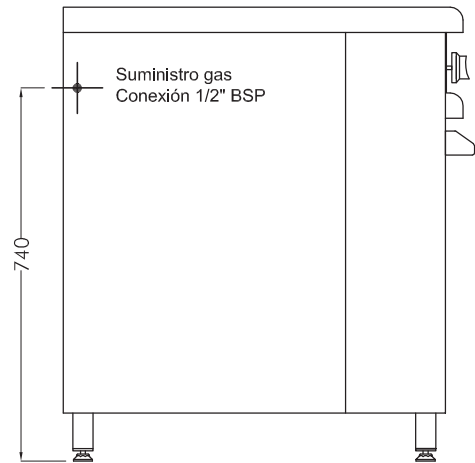

VISTA LATERAL
ESC. 1:15

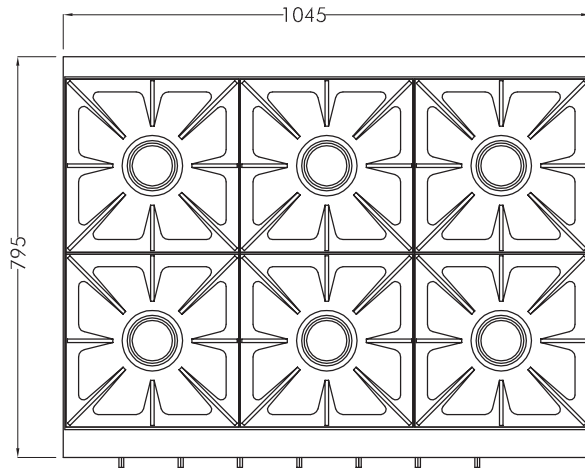

VISTA SUPERIOR
ESC. 1:15

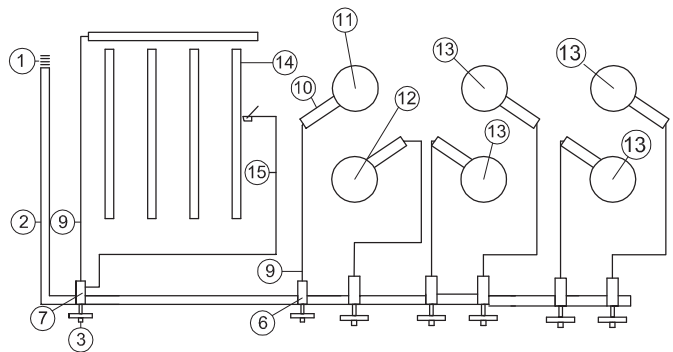

MATRÍCULA Nº 1765

INYECTORES(GAS NATURAL)

DIÁMETRO	CANT.	Kcal/H	TOTAL (Kcal/H)
180	1	4,780	4,780
120	5	2,124	10,620
2,00	4	5,866	23,464
POT. TOTAL (Kcal/H)			38,864

INYECTORES(GAS ENVASADO)

DIÁMETRO	CANT.	Kcal/H	TOTAL (Kcal/H)
120	1	4,049	4,049
0,90	5	2,275	11,375
150	4	6,328	25,312
POT. TOTAL (Kcal/H)			40,736

DETALLES DE ELEMENTOS • COMPONENTES

Nº	DESCRIPCIÓN	MED.	MATERIAL	CANT.
1	1/2NIPPLE	Ø 1/2 x30mm	HIERRO	1
2	VAINA	25x25	HIERRO	1
3	PERILLAS		BAKELITA	7
4	PORTA ROBINETE IND		HIERRO	6
5	PORTA ROBINETE SEMI IND		HIERRO	1
6	ROBINETE IND S/VALV SEG		BRONCE	6
7	ROBINETE SEMI IND C/VALV SEG		BRONCE	1
8	TUERCA DE CONEXION		BRONCE	14
9	CANO (mts)	5/16"	ALUMINIO	8m
10	PIPETAS PARA HORNALLAS		CHAPA	6
11	MECHERO Nº1		FUNDICIÓN	1
12	MECHERO Nº3		FUNDICIÓN	1
13	MECHERO Nº2		FUNDICIÓN	4
14	CANO QUEMADOR	7/8	HIERRO	4
15	TERMOCUPLA	1200	COBRE	1

GAMA GOURMET | COCINA 1045 6 HORNALLAS



De Francesco
EQUIPAMIENTOS COMERCIALES

DIMENSIONES 1045 x 795 x 900mm (Frente x Prof. xAlto)

MATERIAL Acero inoxidable AISI 304 / AISI 430 Esm

ALIMENTACIÓN Gas natural / Gas envasado